

INSTRUCTION MANUAL  
DIGITAL PROGRAMMABLE POWER SOURCE  
MODEL DPS VE 10-2

KIKUSUI ELECTRONIC CORPORATION

82.6.18

823463

On Power Supply Source, it is requested to replace the related places in the instruction manual with the following items.

(Please apply the item of mark.)

- Power Supply Voltage: to \_ \_ \_ \_ \_ V AC
- Line Fuse: to \_ \_ \_ \_ \_ A
- Power Cable: to 3-core cable (See Fig. 1 for the colors.)

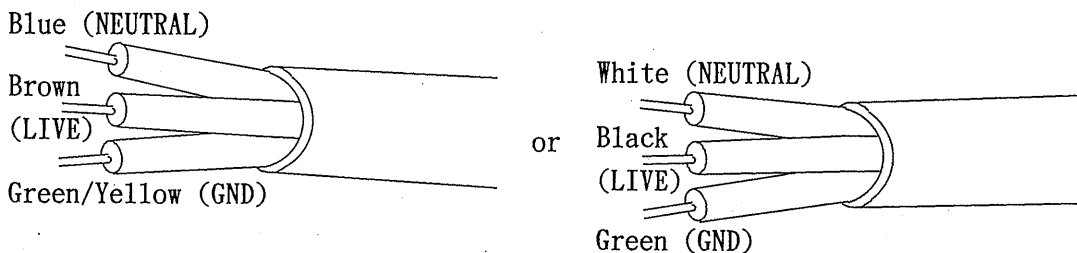

Fig. 1

Please be advised beforehand that the above matter may cause some alteration against explanation or circuit diagram in the instruction manual.

- \* AC Plug: In case of Line Voltage 125V AC or more, AC Plug is in principle taken off and delivered, in view of the safety.  
(AC Plug on 3-core cable is taken off in regardless of input voltages.)  
TO connect the AC plug to the AC power cord, connect the respective pins of the AC plug to the respective core-wires (LIVE, NEUTRAL, and GND) of the AC power cord by referring to the color codes shown in Fig. 1.

Before using the instrument, it is requested to fix a suitable plug for the voltage used.

190. 11. 14

905181

TABLE OF CONTENTS

	PAGE
1. GENERAL .....	1
2. SPECIFICATIONS .....	2
3. OPERATION METHOD .....	4
3.1 Description of Front Panel .....	4
3.2 Description of Rear Panel .....	6
3.3 Pins of Control Input Connector .....	9
3.4 Input Control Signals .....	10
3.5 Precautions for Instrument Operation .....	11
3.6 Preparations for Operation .....	12
3.7 Operation Method .....	13
3.8 Timing Charts for Control Signals .....	14
4. OPERATING PRINCIPLE .....	17
5. APPLICATION .....	19
5.1 Examples of Control of DPS Series .....	19
5.2 Examples of Use of DPS Series .....	20
5.3 Operation in Conjunction with Other Power Supplies..	22
6. MAINTENANCE .....	26
6.1 Layout of Components .....	26
6.2 Adjustment and Calibration .....	27

823464

## 1. GENERAL

The DPS VE 10-2 Digital Programmable Power Source is a constant-voltage constant-current power source designed for use in automatic test systems. Its output voltage can be controlled with an external digital signal.

The output voltage is 0 - 9.99 V, with a 10 mV resolution. The output current is 0 - 2 A, approximately.

When in the external control mode, data can be set with a 12-bit TTL-level negative logic signal. Data can be stored in the internal register by applying a strobe signal when data is ready.

Since address setting is available, a multichannel power source system can be easily compiled.

The output section is electrically isolated from the input control section, providing another convenient feature.

When operated in the internal control mode, the instrument operation can be manually set with digital switches on the front panel. Due to this provision, the instrument can be used not only as a regulated DC power source but also for various applications including the use as a precision constant-voltage source for calibration of electronic devices.

With its external control feature, this instrument can be used for diverse applications such as an IC aging power source, IC tester power source, board checker power source, etc. When used in conjunction with Kikusui Model IF01-DPS Interface, this instrument is capable of GP-IB control and becomes compatible with various types of computers to make up various kinds of automatic test systems.

When used in conjunction with Kikusui Model CM01-DPS Controller, this instrument can be used as a function generator of sophisticated waveforms.

Furthermore, larger power ratings can be readily obtained by using this instrument in combination with other Power Supplies available from Kikusui Electronics Corporation.

## 2. SPECIFICATIONS

Instrument name: Digital Programmable Power Source

Model No.: DPS VE 10-2

Output section

Type: Unipolar constant-voltage constant-current transfer type

Voltage: 0 to 9.99 V

Resolution: 10 mV

Setting accuracy: (0.05% of setting) + (0.03% of FS), at 25°C (77°F)

Temperature coefficient: TYP. 50 ppm/°C

Ripple and noise: 300  $\mu$ V rms or less (at 10 Hz - 1 MHz)

Load regulation: 300  $\mu$ V or less (at rear terminal), for 0 - 100% load change

Line voltage regulation: 0.005% or less, for  $\pm$ 10% line voltage change

Response speed: 1 V/100  $\mu$ sec

Output current: 0 - 2 A, approx.

Setting: Manual setting for approx. 0.2 A or over

Voltage trip: Manual setting for approx. 1 V or over

Control section

Control mode: INT/EXT selectable

INT mode: Control data can be set with digital switches on front panel.

Ext mode: With external control signals

823466

Control signals

TTL level	fan in	3
Data	12 bits	(BCD)
Strobe	1 bit	
Address	4 bits	
Direct zero	1 bit	
Data clear	1 bit	

Output signals:      Address coincidence  
                         Ready

Ambient temperature: 0°C to 40°C (32°F to 104°F)

Withstanding voltage of input/output circuit: 500 V maximum

Power requirements: 117 V ±10%, 50/60 Hz AC, approx. 94 VA (with full load)

Dimensions: 210W × 140H × 310D mm (8.27W × 5.51H × 12.20D in.)

(Maximum dimensions): 215W × 165H × 355D mm (8.46W × 6.50H × 13.98D in.)

Weight: Approx. 6.7 kg (15 lbs.)

Accessories:      Instruction manual      1 copy  
                         50P plug (Amphenol)      1

### 3. OPERATION METHOD

#### 3.1 Description of Front Panel (See Figure 3-1.)

① POWER switch:

Alternate-action type pushbutton switch. When switch is depressed, the instrument power is turned on and the green LED lamp lights.

② OUTPUT terminals:

DC voltage output terminals (binding posts). The red terminal provides a positive DC voltage with respect to the white terminal. The white terminal is connected to the signal ground. The black terminal is connected to the chassis ground. These terminals are connected in parallel with the rear terminals which may be used as sampling terminals.

③ CURRENT dial:

This dial is used for setting the output current. The output current increases as it is turned clockwise. When the current has reached the constant-current level, the red LED lamp above this dial lights.

④ VOLTAGE TRIP dial:

This dial is used for setting the output voltage limiting level. When the set level is reached, the output voltage falls to zero and the red LED lamp above this dial lights. The voltage limit is cleared when the DATA CLEAR signal is applied or when the next data is written.

823468

⑤ CONTROL (INT ↔ EXT) selector switch:

This pushbutton switch selects between internal or remote control. The depressed state is for internal control from the instrument front panel. The extended state is for remote control.

⑥ "DATA SET" digital switches:

These digital switches are used to set data when in the INT control mode of operation. These switches are in a BCD code system. The number of digits differs by Model.

DPS VE 10-2:        9.99        (3 digits)

⑦ STROBE switch:

The Strobe switch is used to write data when in the INT control mode of operation. When this button is pressed, the data set by the DATA SET digital switch is delivered.

692469



3.2 Description of Rear Panel (See Figure 3-2.)

⑧ Terminal block:

OUTPUT										NOISE CASE FILTER	
	S	H	L	S							
⊗	1	2	3	4	5	6	7	8	9	10	⊗

- (1) Sensing terminal for H side. When no sensing is required, short this sensing terminal to terminal (2).
- (2) Output terminal (H side)
- (3) Output terminal (L side)
- (4) Sensing terminal for L side. When no sensing is required, short this sensing terminal to terminal (3).
- (5) Monitor terminal of output current. A voltage signal representing the output current is developed between this terminal and terminal (2). The voltage signal is approximately 1 V for the maximum output current. The full scale value is adjustable with M. A. potentiometer (8-1) .
- (6), (7), (8) Spare terminals
- (9) Case ground terminal
- (10) Center terminal of noise filter of power line. If this terminal is connected to the case ground terminal, a current leak occurs although the filtering effect is improved. Connection of this terminal depends on the type of use.

⑨ Connector

For connection of control input (50-pin connector, Amphenol)

823470

⑩ ADDRESS switches:

These switches are for address setting of this instrument. The top position is for open (the H state or "0") and the bottom position is for shorting (the L state or "1"). When these switches coincide with the address line signals, data can be entered. When the address lines are H.H.H.H or open, the specified state for data entry is attained and data can be entered irrespective of the settings of these switches.

⑪ Fuse:

Fuse of primary circuit of power transformer. Rating 2 A. Turn bracket counterclockwise to remove.

⑫ Power cord:

AC power cord of the instrument. (To be connected to an AC line outlet of correct voltage and frequency.)

⑬ Cord hook:

When the instrument is not in use, the AC power cord may be taken up onto the hooks.

823471

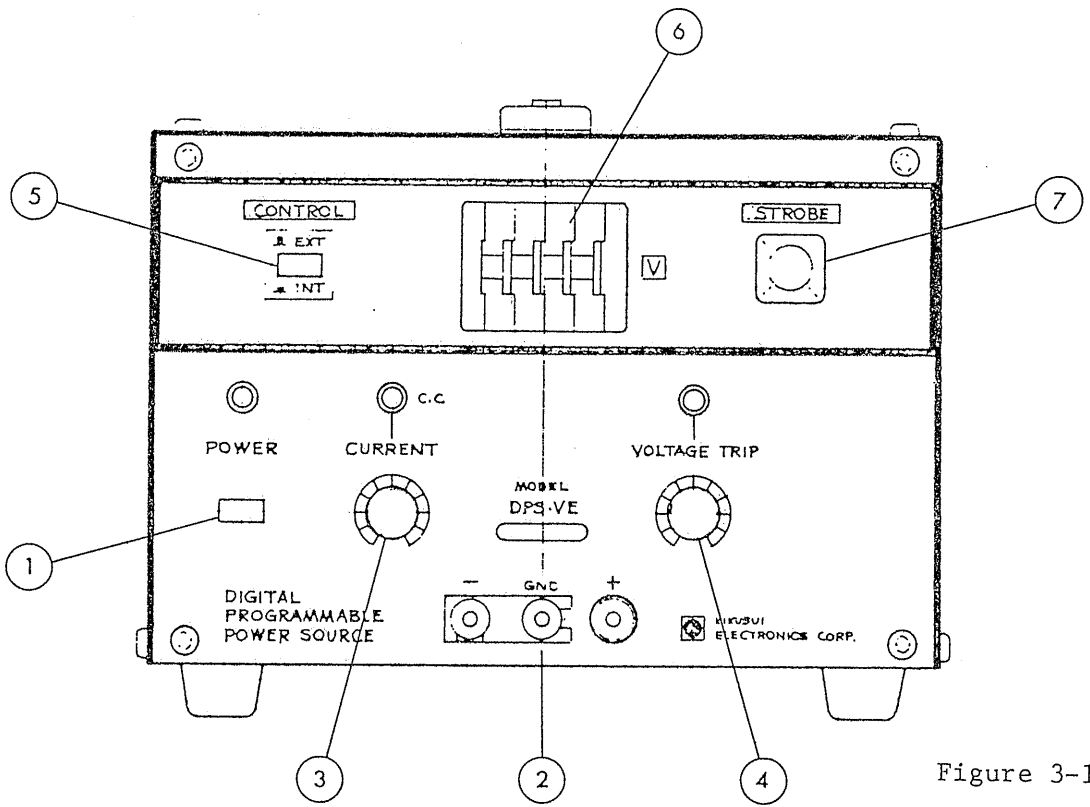

Figure 3-1

M.A (monitor adjustment)

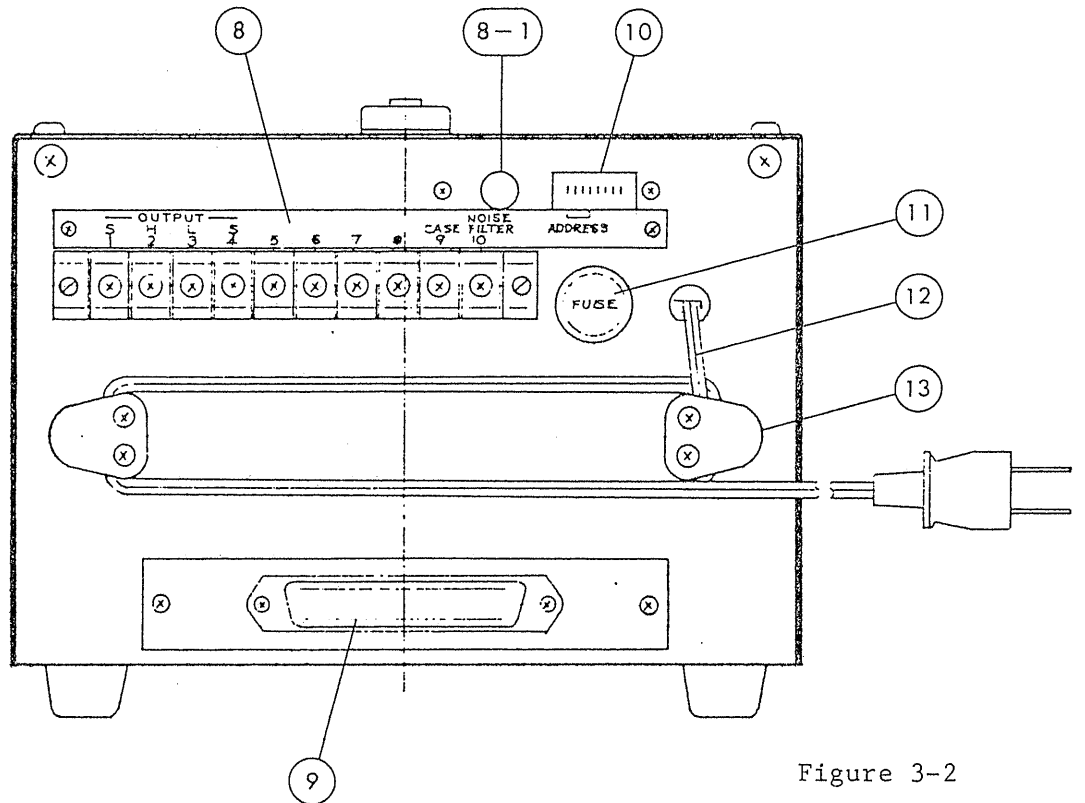

Figure 3-2

### 3.3 Pins of Control Input Connector

1	STROBE	26	1	} LSD
2		27	2	
3		28	4	
4		29	8	
5		30	1	} MSD
6		31	2	
7		32	4	
8		33	8	
9		34	1	} ADDRESS
10		35	2	
11		36	4	
12		37	8	
13		38		
14	DATA CLEAR	39		
15		40		
16	DIRECT ZERO	41		
17		42		
18		43		
19	2 <sup>0</sup> ADDRESS	44	2 <sup>2</sup> ADDRESS	
20	2 <sup>1</sup> ADDRESS	45	2 <sup>3</sup> ADDRESS	
21		46		
22		47		
23	+5 V OUT (approx. 50 mA)	48	READY	
24	ADDRESS COINCIDENCE	49		
25	GND	50	GND	

### 3.4 Input Control Signals

TTL level

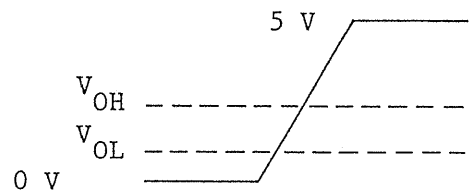
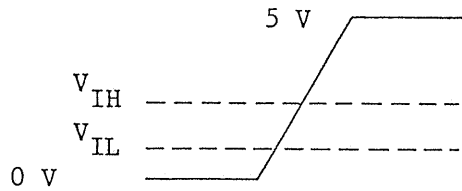

$V_{IL}$ : 0.8 V max.

$V_{OL}$ : 0.4 V max.

$V_{IH}$ : 2 V min.

$V_{OH}$ : 2.4 V min.

$I_{IL}$ : -1.6 mA max. ( $V_{IL} = 0.4$  V)

$I_{IH}$ : 40  $\mu$ A max. ( $V_{IH} = 2.4$  V)

Output voltage control signal	At L level	Operation "1"
STROBE	H $\rightarrow$ L $\rightarrow$ H ( $\square$ )	Operation edge
ADDRESS	Level	Coincidence signal
DIRECT ZERO	At L level	Output is zero irrespective of address.
DATA CLEAR	L level (10 $\mu$ sec or over)	Clearing of data register
READY	H level	
ADDRESS COINCIDENCE	L level	Coincidence of address codes

Note: When address is zero or open, the address codes become zero irrespective of address setting of the instrument.

823474

### 3.5 Precautions for Instrument Operation

- (1) When no sampling is done, be sure to short the sampling terminals on the rear panel to the corresponding output terminals with the shorting bars supplied. Note that the accurate output voltage may not be obtained unless these shorting bars are securely connected.
- (2) Operate this instrument in a well ventilated place, and avoid overheating.
- (3) The control input/output connector pin 23 provides a 5 V output. This output is used for a Kikusui controller. This output power has a diode connected in series and it is delivered in a drop-out state.
- (4) Make sure that the control signals and edge signals are of the accurate levels and sharp edges. (See Section 3.8.) Note that errors may occur if these requirements are not met.
- (5) Pay attention to the timing of the control signals. (See Section 3.8.)
- (6) The withstanding voltages of the instrument between the control circuit and the output circuit, between the control circuit and the chassis, and between the output circuit and the chassis are 500 V. Note that the instrument may be damaged if a voltage higher than this limit is applied.
- (7) The VOLTAGE TRIP circuit of this instrument trips when the circuits are operating normally, unlike the OVP circuit.

823475

### 3.6 Preparations for Operation

- (1) Connect the power cord to an AC line outlet of the correct voltage and frequency.
- (2) Turn on the power switch.
- (3) The instrument is ready for operation several minutes after turning on the power. When high accuracy is required, allow a stabilization period of 30 minutes or more.
- (4) Set the CURRENT dial as required.
- (5) Set the VOLTAGE TRIP dial as required. If no voltage trip function is required, set this dial in the extreme clockwise position.
- (6) Set the MODE (INT ↔ EXT) switch as required.
  - \* When the instrument power is turned on, the internal register is cleared and the output voltage is zero.
- (7) When in the INT mode of operation, set the desired value with the digital switches and press the STROBE switch.
- (8) When in the EXT control mode of operation and address specification is required, set the address switches to the desired address. Enter data and strobe signal with the timing as explained in Section 3.8.

823476

### 3.7 Operation Method

- (1) Set the address. When a single instrument is used as an independent unit, no address setting is required if address lines (pins 19, 20, 44 and 45) are H ("0" or open).
- (2) Program the data in BCD-code negative logic and apply the strobe signal.
- (3) The output for the set value will be delivered.

- o DIRECT ZERO

When pin 16 is set in the L state, the output voltage is electrically maintained at zero irrespective of address specification.

- o DATA CLEAR

When pin 14 is set in the L state (for 10  $\mu$ sec or over), the internal register and trip display register are cleared irrespective of address specification.

- o READY

When pin 48 is in the H state, data entry is ready. See Section 3.8 for timing.)

- o ADDRESS COINCIDENCE

If there exists on the control lines an instrument which has the same address as specified on the unit, pin 24 switches to the lower (L) position.

When in the INT control mode of operation, the control lines are in the H level irrespective of address specification.



Example of input operation

Setting for 9

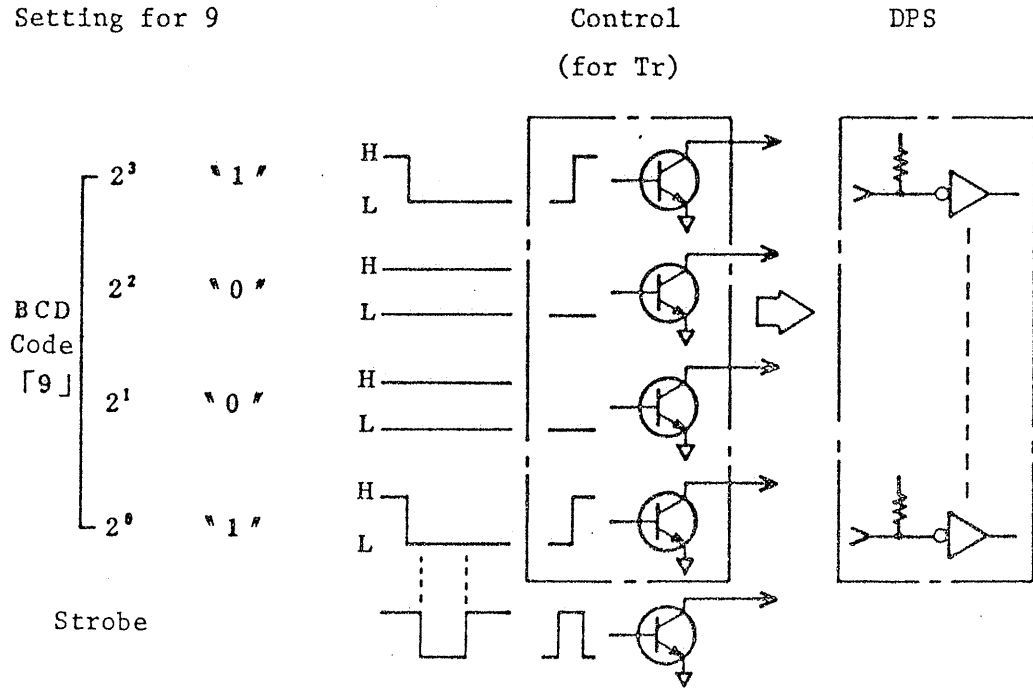

3.8 Timing Charts for Control Signals

(1) When power is on

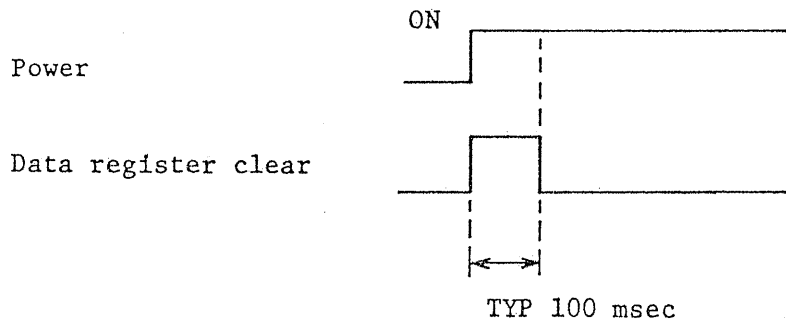

823478

(2) Data write

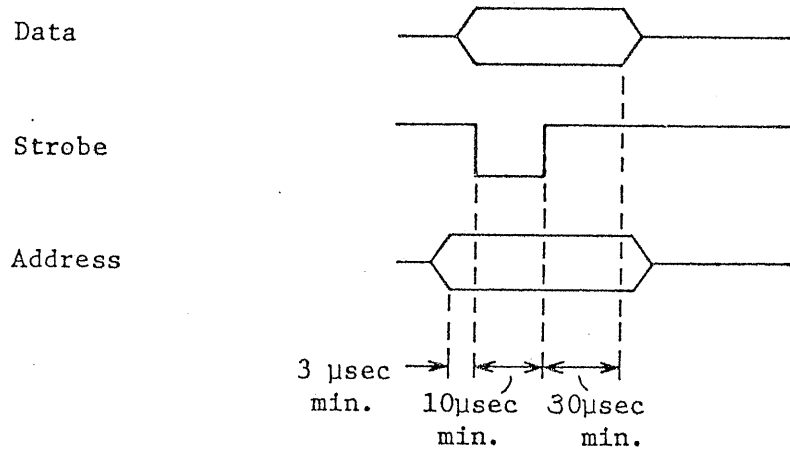

When a single unit of DPS is operated independently, it can be controlled without any address setting. In this case, however, the width of the strobe signal will be as indicated above.

(3) DIRECT ZERO

Output (amplifier)

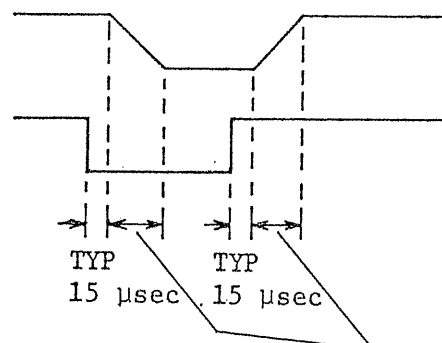

Speed of output amplifier

(Reference:  
Approx. 1 V/100 μsec)

(4) DATA CLEAR

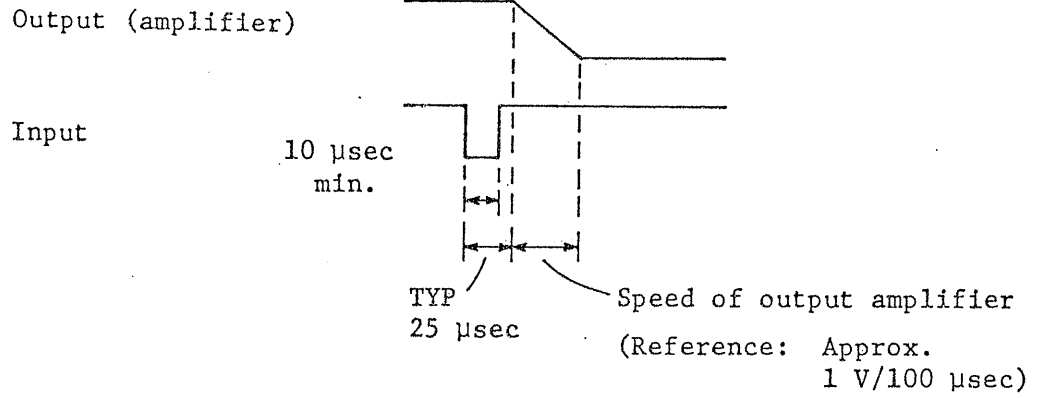

(5) READY

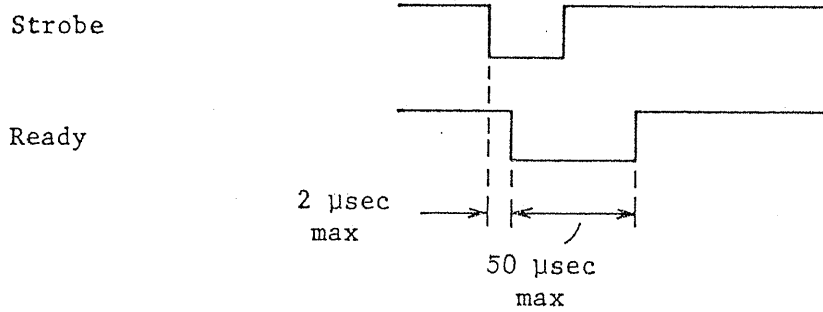

(6) ADDRESS COINCIDENCE

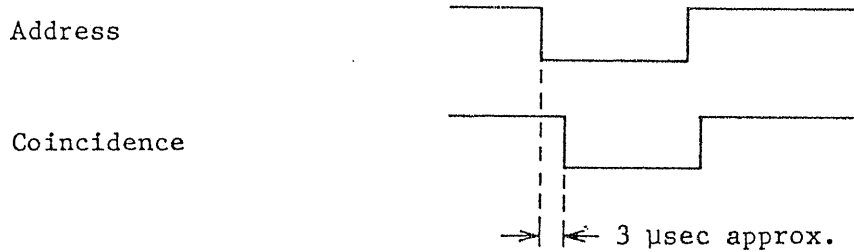

#### 4. OPERATING PRINCIPLE

The circuit construction of this instrument is shown with a block diagram in Figure 4-1.

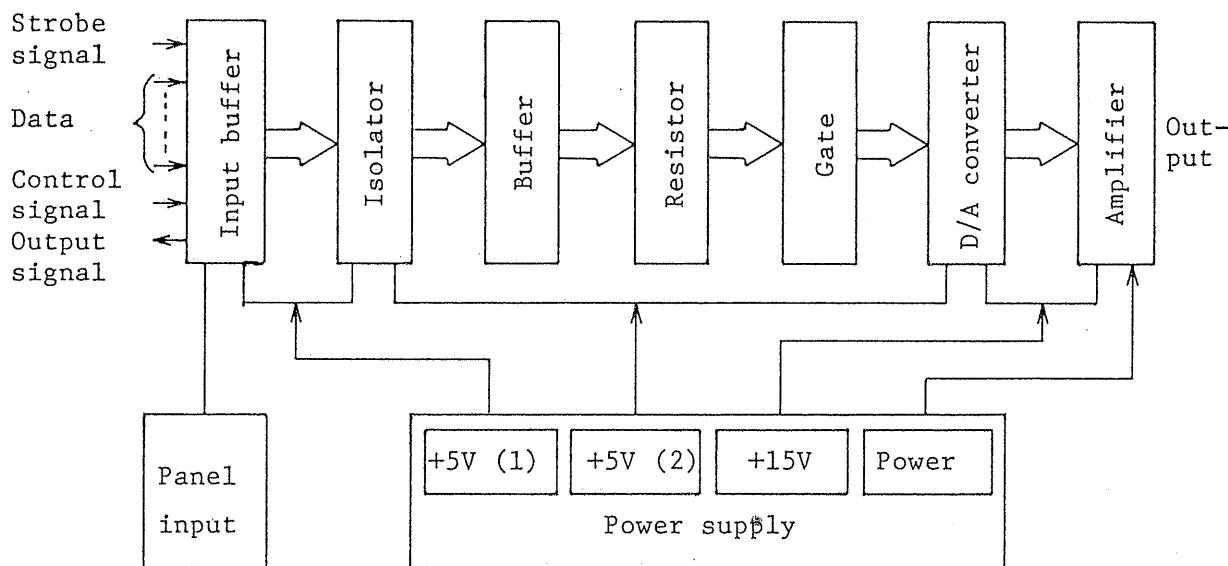

Figure 4-1

The amplifier is a constant-voltage constant-current transfer type, with a construction as shown in Figure 4-2.

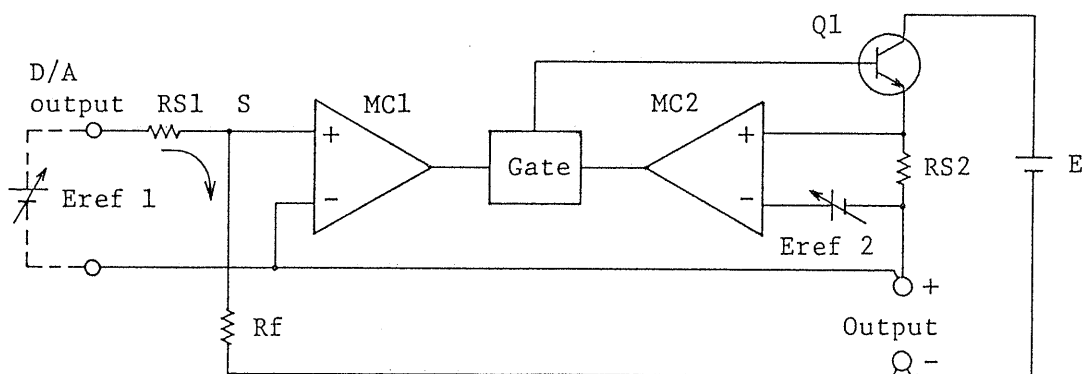

Figure 4-2

- |           |                                  |         |  |
|-----------|----------------------------------|---------|--|
| MC1:      | Constant-voltage error amplifier | Eref 1: | Reference voltage for constant-voltage operation (output of D/A converter) |
| MC2:      | Constant-current error amplifier | Eref 2: | Reference voltage for constant-current operation                           |
| RS1, RS2: | Sampling resistors               | Q1:     | Control transistor   |
|           |                                  | E:      | Nonregulated power supply  |

823481

The data or control signal applied to the input buffer is isolated by a photocoupler and fed to the secondary control circuit.

The signal attenuated in the photocoupler is amplified again by the buffer and then it is applied to the register. The signal which is stored by application of the strobe signal is fed to the D/A converter via the gate circuit. The converted analog signal is amplified by the amplifier and fed to the output circuit.

The amplifier operates as follows: When in the constant-voltage mode, constant-voltage error amplifier MC1 is connected to control transistor Q1 through the gate circuit. Since a negative feedback circuit making up a closed loop is provided, the potential difference between the inverted input terminal of MC1 and non-inverted terminal is automatically reduced to zero, a relationship of  $E_{ref} / R_{s1} = i$  is maintained, and reference current  $i$  flows. Current  $i$ , which cannot flow into MC1, flows through  $R_f$  and it is fed back through E and Q1. Current  $i$  which flows through resistor  $R_f$  produces a voltage drop  $R_f \cdot i$ . One end of resistor  $R_f$  is connected to the negative output terminal and the other end is connected to the positive terminal of MC1. The positive and negative terminals of MC1 are at almost same potentials and the negative terminal is connected to the positive output terminal. Therefore, the voltage  $R_f \cdot i$  corresponds to the output voltage.

Now assume that the output voltage has fallen below the set output voltage. The potential of the positive terminal of MC1 becomes higher than that of the negative terminal. Consequently, the output of MC1 increases and the control transistor is turned on to increase the output voltage in order to return to the equilibrium state at the set voltage. When the output voltage has risen above the set voltage, the control transistor operates in such a manner that the output voltage is lowered toward the equilibrium state at the set voltage.

When the output current has increased and the voltage drop across the constant-current sampling resistor has reached the reference voltage  $E_{ref} 2$ , the gate circuit is switched and the constant-current error amplifier MC2 is connected to control transistor Q1 and the operation is transferred into the constant-current mode. The reference voltage  $E_{ref} 2$  is adjustable with the CURRENT potentiometer dial on the front panel of the instrument.

823482

## 5. APPLICATION

### 5.1 Examples of Control of DPS Series

(1) Direct control with CPU

CPU: Various controllers (computers, digital equipment, etc.)

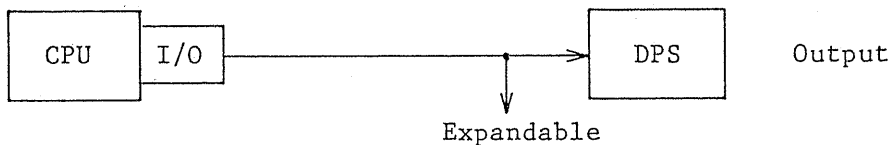

(2) Control with standard interface

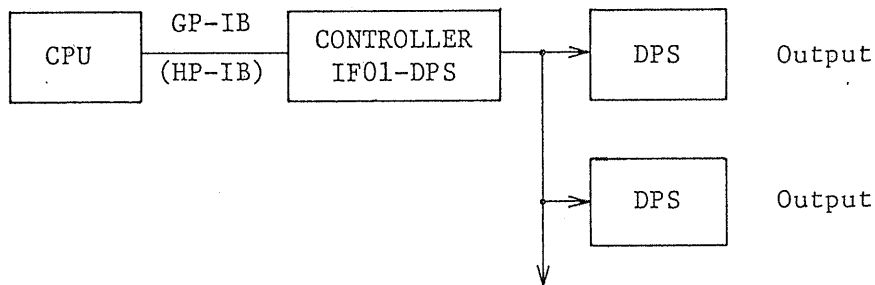

Up to 15 units can be controlled.

(3) Function generation with Kikusui Model CM01-DPS

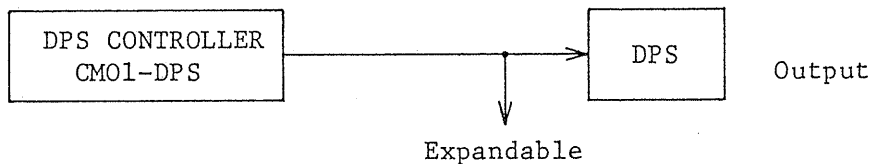

Non-volatile memory of 64 steps available

(4) Remote control

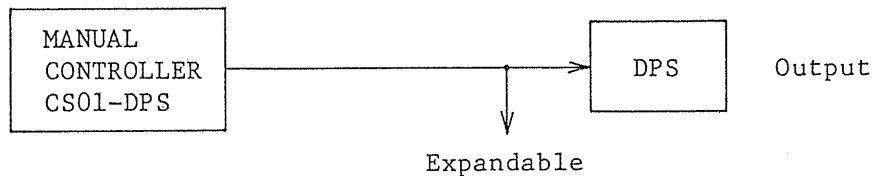

R23483

## 5.2 Examples of Use of DPS Series

- (1) For programmable control of generator

Oscillating frequencies of a frequency generator can be program-controlled. For example, apply the DPS output to the VCG (voltage-controlled generator) terminal of a function generator.

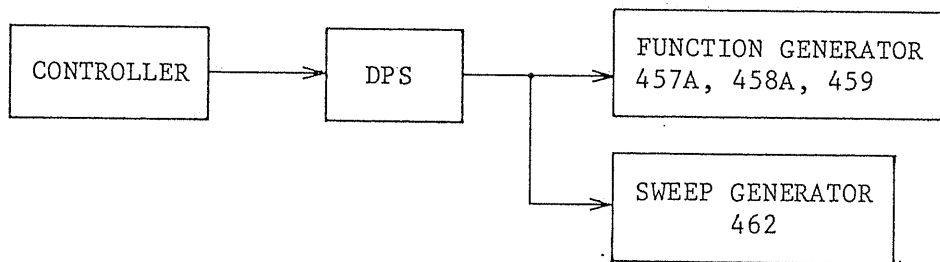

Output amplitude control also is programmable. For example, apply the DPS output to the VCA (voltage-controlled amplitude) terminal of a function generator.

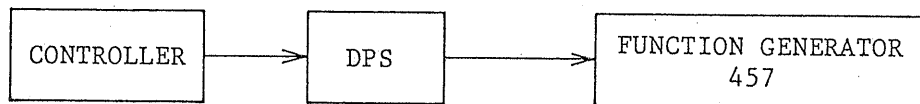

- (2) To use as a simple D/A converter

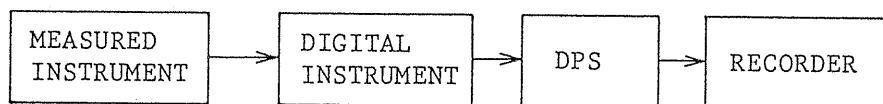

823484

- (3) To use as a signal source (for example, for impurity density measurement of semiconductors)

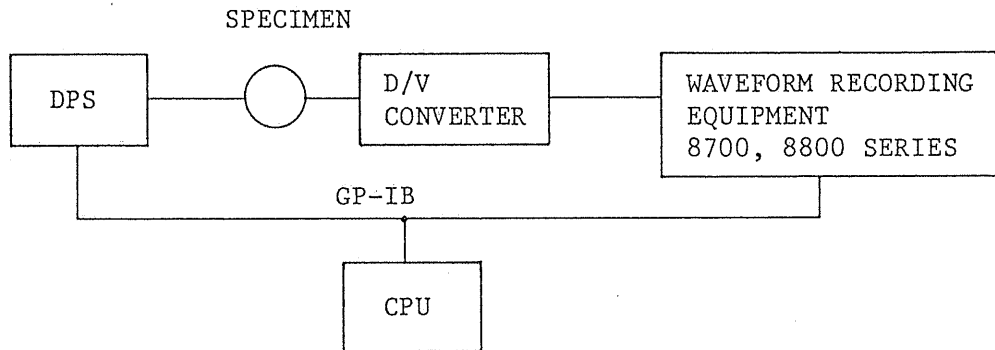

- (4) For digital control of outputs of large ratings

For DC voltage/current:

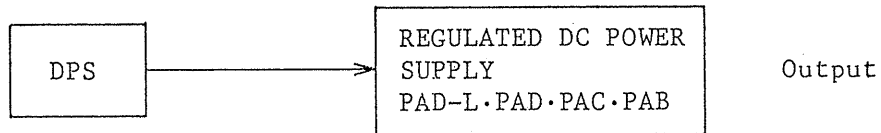

(Minor modification is required. For connection method, see Section 5-3.)

For bipolar power:

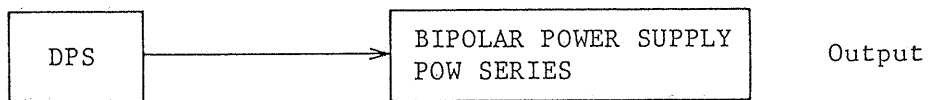

For constant-current load device:

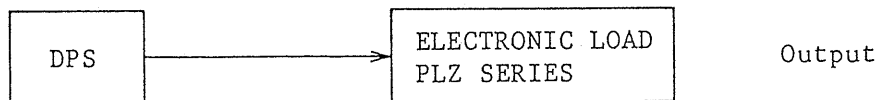

823485



### 5.3 Operation in Conjunction with Other Power Supplies

#### (1) Series Operation

By connecting power supplies in series, a high resolution adjustable output voltage can be obtained.

**Note:**

When overloading occurs and the protecting circuit of one of the units has failed, the output voltage of the other unit is applied in the reverse polarity to the former unit and its series control element may be damaged. In order to guard against this, a diode must be connected between the output terminals of each unit.

When in a parallel operation is the withstanding voltages of the terminals with respect to the chassis ground must not exceed the specified value.

Before connecting the actual load and starting operation, be sure to test the set up using a dummy load to check that the electrical connections and response speed are correct and there is no abnormal state such as oscillation.

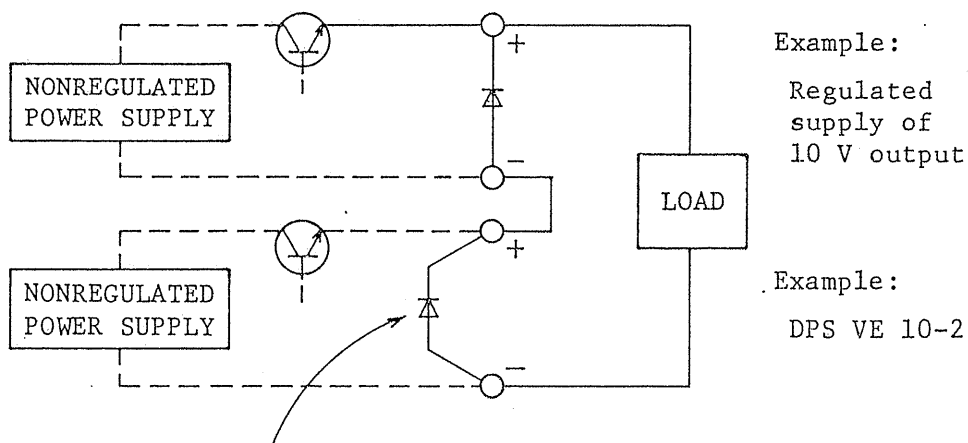

The output terminals of DPS VE are connected with a diode inside the instrument.

The output voltage is adjustable for a range of 10 V - 19.99 V with a resolution of 10 mV.

Be sure to turn off the power switches before making electrical connections.

(2) One-control Parallel Operation

When an output current larger than the rating of this instrument is required, this instrument may be used as a master unit and Kikusui PAD-L or PAB Series Power Supply instrument may be used as a slave unit.

Be sure to turn off the power switches before making electrical connections. For electrical connections, refer to the paragraphs related to one-control parallel operation in the instruction manual of the slave unit.

Example: To use a PAB Series instrument as a slave unit

- (1) Change the parallel-operation selector switch on the rear panel of the slave unit from "M" to "S".
- (2) Connect terminal 5 of the rear terminal block of the master unit to connector J4 of the slave unit.
- (3) Connect in parallel the master unit output and slave unit output.
- (4) Turn the CURRENT and VOLTAGE dials of the slave unit to the extreme clockwise position.
- (5) Turn the CURRENT dial of the master unit to the extreme clockwise position.
- (6) Turn the M.A (monitor adjustment) potentiometer on the rear panel of the master unit to the extreme counterclockwise position.
- (7) Connect to the output circuit a dummy load which will drain the required current.
- (8) Turn on the master unit power first and the slave unit power next.

- (9) Write the maximum voltage of the range to be used. The constant-current mode indicator LED lamp of the master unit will light up.
- (10) Turn the potentiometer which is on the rear panel of the master unit clockwise. The current of the slave unit will increase and the voltmeter reading will rise.
- (11) Set the potentiometer at the point where the constant-current mode indicator LED lamp goes off and the operation of the master unit is transferred to the constant-voltage mode.
- (12) Check that the response speed is normal and there is no oscillation or other abnormal state. Then, turn off the slave unit power first and the master unit power next.
- (13) Connect the actual load. The power source is ready for operation.

Example: To use a PAD-L Series instrument as a slave unit

- (1) Disconnect the shorting bars from terminals 2 and 3 of the rear terminal block of the slave unit.
- (2) Connect terminal 5 of the rear terminal block of the master unit to terminal 3 of the rear terminal block of the slave unit.
- (3) Perform the procedures of Steps (3) through (13) explained in the preceding example.

To use this instrument with Kikusui Power supply instruments other than those mentioned in the above, minor modifications are required. For such use, contact your Kikusui dealer.

Notes for use of this instrument in combination with other power supply instrument:

- (1) If the response speeds differ largely from master unit (DPS) to the slave unit, rise up response may not be smooth.

Due to the electrolytic capacitor connected between the output terminals of the slave unit, the output may be accompanied by overshoots. Such overshoots may be reduced by connecting a bleeder resistor to the load.

- (2) When a transformer tap switching type instrument (PAB instrument) which has an internal switching relay is used as a slave unit, avoid rapid change or repetitions near the switching point of the relay.

## 6. MAINTENANCE

### 6.1 Layout of Components

To gain access to the internal components, remove the case cover after removing its six clamping-screws. Layout of major internal components is shown in Figure 6-1.

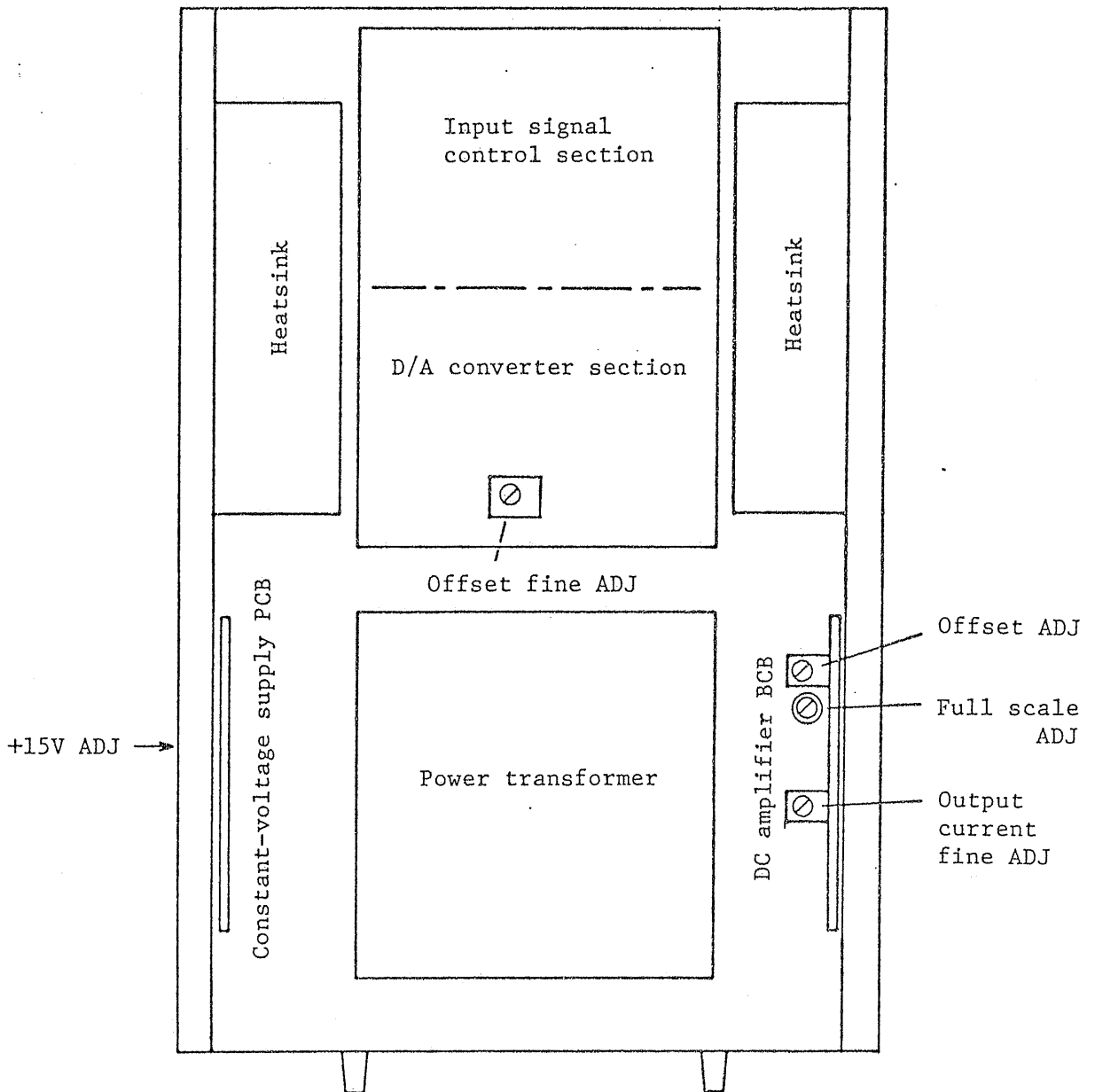

Figure 6-1 (Top view)

823490

## 6.2 Adjustment and Calibration

It is recommended to adjust and calibrate the instrument periodically (once in every six to twelve months). Calibration should be performed in stable ambient temperature of approximately 25°C (77°F). After turning on the instrument power, allow a stabilization time of 30 minutes or more.

To adjust and calibrate the instrument, set the CONTROL mode selector switch in the INT position and proceed as follows:

(1) DC amplifier offset adjustment:

Set at 0.01 and adjust the output at 10 mV.

(2) DC amplifier full-scale adjustment:

Set at 9.00 and adjust the output at 9.00 V.

(3) When the limit point of the output current has been shifted, adjust it with the output current fine-adjustment potentiometer on the DC amplifier printed circuit board.